

# Pallet Truck Scale

PT.WW

- Weighing pallet truck.
- Structure in powdered painted steel.
- Wheels of cast steel and polyurethane external coating.

## Indicator

- ABS housing LCD display. With steel impact protection part.
- IP54 protection.
- Units kg and lb.
- Bubble level.
- Rechargeable internal battery 6V 4,5Ah.
- Power supply with adaptor AC/DC 100-240Vac 50/60Hz.
- Operating temperature -10°C a 40°C.



# Pallet Truck Scale PT.WW

## Features

- Accumulation
- Zero
- Tare
- Gross/ Net
- Piece counting function
- Checkweighing function
- Hold function
- Weight for percentage



PCS



PRINT INC



BAT INT



AC/DC



IP54



NO VERIF

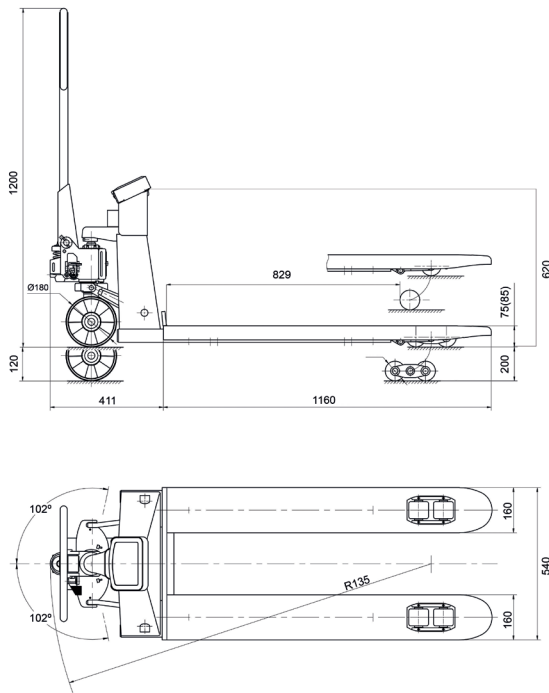

**WEIGHTRON** BILANCIAI  
**BILANCIAI** INDUSTRIAL WEIGHING SPECIALISTS GROUP

## Head Office

Titan Works,  
 Bridge Way,  
 Chesterfield Trading  
 Estate,  
 S41 9QJ

0808 196 0906  
[sales@weightroncb.co.uk](mailto:sales@weightroncb.co.uk)  
[www.weightron.com](http://www.weightron.com)

## Technical Specifications

CODE #	Capacity (kg)	Readout (g)	Packing Dimensions (kg)	Packing Weight (kg)	Certifications (ENAC)
PT.WW	2000	500	1600 x 600 x 1400	118	900004

Agent / Dealer