



# Weighing terminal



model **D520**



# D520 weighing terminal

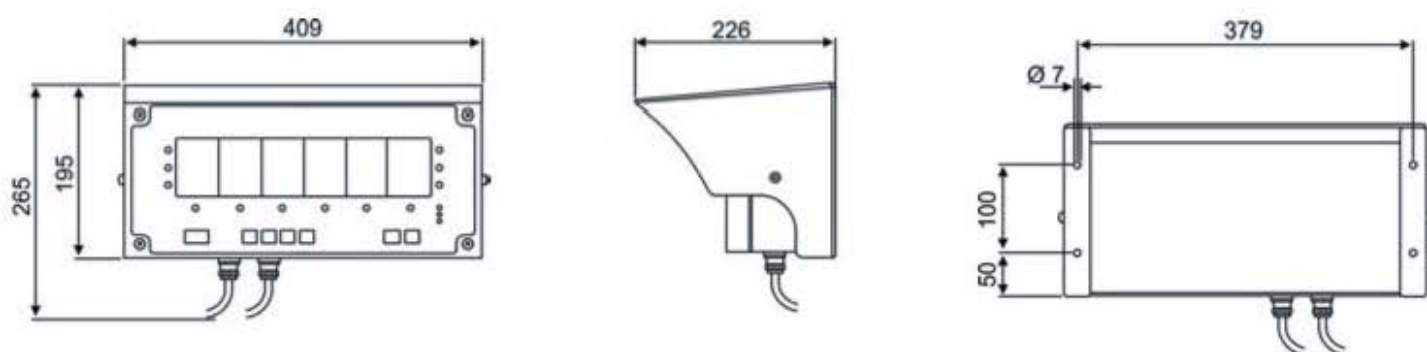

## Main features

Weighing terminal with high-intensity display directly connectable to the weighing platform. Simple, versatile and easy to read from long distances because of its high-density display. Contained in an IP65 stainless steel casing with supplementary indications according to OIML regulations. Complete with protective shield and stainless steel fastening bracket for a wide range of application solutions.

Equipped with 2 serial outputs for connection to external devices, such as PCs, printers, etc.

It can be equipped with a radio control for remote function control.

Homologated according to EN455 01 standards.

## Technical specifications

	D520
Power supply	110-230 V
Connectable load cells	Up to 4 analogue cells of 350 ohm (or 8 of 700 ohm)
Load cell power supply	10Vdc
Internal resolution	200,000 points with 25 conv/s
Maximum number of divisions in homologated version	6,000 divisions or two ranges of 3,000
Outputs	1 RS232 serial output - 1 RS232/485 serial output
Protection	IP65

## Options

Radio transmission in Wi-Fi mode

433 MHz, 868 MHz or Zigbee radio transmission

Radio control



**SOCIETÀ COOPERATIVA  
BILANCI AI**

Strumenti e Tecnologie per Pesare

41011 Campogalliano (MO) - Via S. Ferrari, 16  
Tel. 059.89.06.11 r.a. - Fax 059.52.79.99  
www.coopbilanciai.it - eb@coopbilanciai.it